

Anywhere Virtual 3-Way Switch Kit for remote virtual lighting control - Two switches replace existing switches and provide 3-way virtual control – no traveler or batteries needed

- **Virtual ON/OFF control of 2 circuits from 1 switch location - add more locations with model US1-V0 and US2-V0, or Anywhere Virtual Accessory Modules**
- **2-rocker switch's top rocker controls local circuit (and devices set on channel 2), bottom rocker controls remote switch (and devices set on channel 1)**
- **Compatible with LED, incandescent, Halogen, fluorescent, low-voltage lighting and motors -pump/fan (900 W / 7.5 Amps max., 1 W min.)**
- **Vapor (Sodium/Mercury) or metal-halide lights may require isolation (model ZNF10A-W) filters.**

IMPORTANT!
Read This Before Installing!

- **DO NOT WIRE HOT!** Permanent damage may result. Improper installation voids the warranty. If necessary pull out LED indicator light-pipe (1/4 inch) to disconnect power and avoid damage.
- **Switches require hot and neutral connections.**

Anywhere Virtual 3WAY-B Switch Kit (2-Rocker) is shown with detachable, white-rocker faceplates. Color change rocker kits sold separately (see model ZS11 and ZS22).



FUNCTION

Model V3WAY-B Anywhere Virtual 3-Way Switch Kit includes 2 high quality, professional grade, on/off switches with gloss white faceplates (models US2-V02 and US1-V01). They are used to replace existing mechanical switches and use the existing switch wires (white neutral wire required) to provide 3-way control - no traveler wires or batteries needed. The Anywhere Virtual 3-Way Switch Kit offers a cost effective alternative for the professional electrician – versus running costly new wiring or using wireless 3-way consumer DIY options that do not always work. For 4-way or 5-way or more-way applications, one or more of the Anywhere Virtual Accessory Switches (**US1-V0 or US2-V0**) can be used to work in unison with the **V3WAY-B** switches.

Each switch has a (900W Max., 1W Min.) output circuit wire that can be connected to control a local light/load circuit. Straight out of the box (factory default) the top-rocker of the 2-rocker US2-V02 controls the switch's output circuit wire; and the bottom-rocker controls the remote virtual US1-V0 switch. Pressing the top of the rocker (top-rocker on US2-V0) turns on the output (status LED shines green). Pressing the bottom of the rocker off the switch's output (status LED shines blue).

The 2-rocker US2-V02 switch uses the top-rocker to control its output and remote devices set on channel 2. The bottom rocker controls the single rocker switch (US1-V0), which is set on channel 1 (factory default) and any number of other Anywhere devices set on channel 1. The rocker-channels of the US2-V0 are fixed. The channel(s) used by US1-V0 can be changed manually to use any one of 4 channels. The US2-V0 switch base can also be use with a 3- or 4-rocker faceplate (ZS23 or ZS24) for up to 4-zones of lighting control. Simply remove and replace faceplate. The switches also have a thermal overload protection mechanism. It will momentarily turn the switch off if it gets too hot. This prevents accidental overload (e.g. someone changes bulbs to a wattage exceeding maximum) from damaging the switch or causing a safety issue. The switch will turn back on after it cools. Thus an overloaded switch will cycle off/on/off/on... until the switch is turned off or the load is reduced to within specifications.

The professional grade Anywhere Virtual 3-Way Switch Kit and Accessories employ Simply Automated's advanced powerline communication technology. This technology is safe and reliable. It has no radio frequency (RF) emissions, and is used reliably in tens of thousands of homes with no adverse affects to appliances, stereo equipment, ham radios, cordless phones, wireless RF modems/devices, computer equipment or other home automation technology like the much less reliable X10. In fact the technology is employed in freeway bridge applications spanning over a mile. The Anywhere Virtual 3-Way Switch Kit is compatible with Simply Automated's Anywhere Switches and Accessories, including: Anywhere Switches (US1-V0 & US2V0), controlled receptacle (URD-V0), plug-in (UMA-V0) and wire-in (UFR-V0) relay modules. 'Anywhere' switches and accessories are **not compatible (will not talk to or work) with any of Simply Automated's PC-Configured, Pre-Configured, SimplySmart™, or other UPB or UPstart configured product solutions.**

IMPORTANT SAFETY INSTRUCTIONS

When using electrical products, basic safety precautions should always be followed, including the following:

1. READ AND FOLLOW ALL SAFETY INSTRUCTIONS.
2. Installation should be performed by a qualified electrician.
3. Keep away from water. If product comes into contact with water or other liquid, disconnect immediately.
4. Never use products that have been dropped or damaged.
5. Do not use this product outdoors (unless protected from moisture).
6. Do not use this product for other than its intended use.
7. Do not connect multiple lamps that, when combined, exceed the maximum load rating of the product, de-rated for multi-gang boxes.
8. Do not install in areas that can exceed 120°F (e.g., in an attic).
9. To avoid the risk of overheating and possible damage to other equipment, do not wire this product directly to a receptacle.
10. Do not cover the product with any material when in use.
11. SAVE THESE INSTRUCTIONS.

INSTALLATION

The Anywhere Switches are designed to be installed in a junction box that is wired to a readily accessible over-current protection device in the building wiring per NEC and CEC electrical codes.

CAUTION: DO NOT CONNECT TO RECEPTACLE – USE MODEL URD-V0 CONTROLLED RECEPTACLE. The default switch configuration operates as an on/off switch; using a single tap to the top/bottom of the rocker to turn on/off.

ATTENTION: NE PAS SE CONNECTER A RECIPIENTS. La configuration du commutateur par défaut fonctionne comme un interrupteur marche / arrêt, à l'aide d'une simple pression vers le haut / bas de la bascule pour activer / désactiver.

 **CAUTION: DO NOT WIRE THIS DEVICE WITH POWER CONNECTED.** Injury or permanent damage to the device may result. Improper installation voids the product warranty.

1. Locate the two existing wall switches where the Anywhere Virtual 3-Way Switch Kit will be installed. Note that the lamp rating (or the combined rating of all connected lamps/loads) on each switch must not exceed what is shown in the de-rating table below.

Table 1: Power per Dimmer		Number of US1/US2 Switches in J-box		
		1	2	3+
Number of J-box Gangs	1	600W	--	--
	2	800W	500W	--
	3+	900W	700W	500W

2. Disconnect power at the circuit breaker for each switch circuit.
3. Remove the existing wall switches. Disconnect the wires to the switches.
4. If a color change kit will be used to change out the faceplates, remove the white faceplate and install the desired faceplate. See "INSTALLING/CHANGING FACEPLATES" for details.
5. At each switch location use a wire nut to connect all white (Neutral) wires together. Make sure the connection is tight and strong to ensure good communication between switches.

- At each switch location use a wire nut to connect the brown (load output) wire of the switch to the black wire of the load/fixture to be controlled.
- At each switch location use a wire nut to connect the black (Line) wire of the switch to the black (Line) power wire. Make sure the connection is tight and strong to ensure good communication between switches.
- Mount each switch inside their respective J-box using captive screws. **DO NOT OVER TIGHTEN THE SCREWS.**
- Reconnect power at the circuit breakers.
- Press and release (tap) top of rocker to turn on respective switches, press and release (tap) bottom of rocker to turn off respective switches (or any Anywhere accessories).

WIRING DIAGRAM

Anywhere switches require a hot (line) and neutral connection. The brown load wire connects to the lighting circuit (switch leg). If no lighting circuit is needed at the output of one switches, then cap that switch's brown wire with a wire nut.

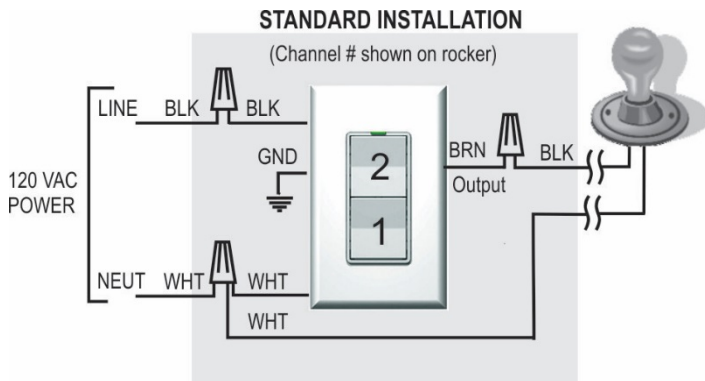

POWER DISCONNECTION

To disconnect power to the switch and connected lamp fixture, depress the top of the rocker switch, grab the underside of the clear plastic indicator tab (light pipe) with your fingernail, and pull the tab out 0.2" until it stays in place. The LED indicator will extinguish, showing that power is now disconnected. To reconnect power, simply push the tab back into its normal position. Utilize the 'disconnect' to prevent damage if wiring hot.

CHANGING CHANNELS

If separate 'sets', or lighting 'zones', of Anywhere Virtual 3-Way Switch Kits or Anywhere Remote Lighting Control Accessories will be used on the properties' power service, then the other 'set' of switches and accessories will need to be configured for a channel other than # 1 & 2 (default). There are four (4) available channels to use and changing them is easy. To change the channel used by the Anywhere US1-V0 switches and accessories, do the following (US2-V0 transmit channels 1 & 2 are fixed – cannot be changed):

- Go to the first US1-V0 switch. Press and hold the rocker down (approximately 6 seconds) until the status LED flashes green, then release. Status LED should be flashing green.
- Tap the rocker 2 times for channel #2 (or 3 times for channel #3, or 4 for channel #4). The LED will stop flashing.
- Repeat steps 1 and 2 for the other switch(es) or accessories that need to communicate on the desired channel making sure you tap in the same channel number.
- Test the switches to make sure they are communicating on the same channel and controlling each other. If there is some issue between the switches, try entering the channel number (for all switches using the specific channel) again, using steps 1 and 2 above.

Helpful Hint: Anywhere Switches use the powerline to communicate. If the switches are not controlling each other, phase alignment is a good way to help the switches talk. Swap breakers/wires at the breaker panel so switches are on the same phase (both on A, or both on B), or use phase coupling (see model ZPCI) when phase alignment is not feasible.

FACTORY DEFAULT SETTINGS

To restore the switch to the original factory default settings (e.g. Channel #1), tap the rocker 5 times quickly. The LED will flash green. Then tap the rocker 10 times quickly. The LED will flash blue. Tap the rocker 2 times quickly and the LED will stop flashing. At this point the switch is reset.

INSTALLING/CHANGING FACEPLATES

Anywhere Switches are designed with removable actuator faceplates, making it possible to change color in the field without disconnecting the switch from the wall.

To remove the faceplate assembly to change color, do the following:

- If installed in a junction box, remove the wall plate framing the switch.
- Using the thumb and index finger, press the top two side-prongs of the rocker faceplate assembly inward so that they unlatch from the switch body. This will release the top of the rocker assembly.
- Press the two lower side-prongs inward, and pull the faceplate assembly away and slightly downward from the switch body, moving it away from the clear plastic light pipe.
- Once the faceplate is removed, follow steps 1-4 below for instructions on installing a new rocker faceplate assembly.

To install a faceplate assembly, do the following:

- Hold the actuator faceplate assembly so that clear plastic light pipe (LED) on the switch fits nicely into the recess on the top of the faceplate.
- Align the four prongs on the side of the faceplate assembly with the four slots on the switch body.
- While squeezing the prongs on both sides, press the faceplate straight onto the switch body. Ensure that all four prongs are fully inserted and latched into the switch body. If all four prongs are not fully latched, the rocker plungers may not function properly.
- Exercise rocker several times to ensure proper seating and operation. If the rocker doesn't operate properly, remove and re-install the faceplate to check proper seating and operation.

TROUBLE SHOOTING

Simply Automated's Powerline technology is extremely robust. Using large low frequency pulses in a patented pulse position modulation protocol, they can overcome power line noise and capacitive attenuation in most (98%) applications. In the event that the switches are set for the same channel, but are not communicating (i.e. turning each other on/off) or controlling the local light/load circuit(s), here are steps to diagnose and resolve the issue:

- Are the LED indicators lit on both switches, indicating the switches are powered? If not, make sure the Power Disconnect (LED light pipe) is pressed in, check hot and neutral wire-nut connections and circuit breaker state.
- Do both the switches' LEDs change from blue to green when turning from off to on? If not, check hot and neutral wire-nut connections making sure the connection is tight and strong for good communication. If yes, then check the brown load wire connection to the fixtures' switch leg, and if necessary the light fixture and bulb. A volt meter or power indicator probe is helpful in confirming switch leg power vs. bulb/fixture fault.

At this step one switch should be turning the lighting circuit on/off. Or if each switch has a connected lighting circuit then each switch should be able to control its own lighting circuit. If they are not controlling each other, double check they are on the same channel (try resetting to factory default as described above). If they still don't control each other there would appear to be a communication issue, and phase alignment (swap breakers/wires so both switched are on the same phase, either phase A or B) or installing a phase coupler (model ZPCI) may be necessary. For additional trouble shooting assistance, please call or write Simply Automated Technical Support at 800-630-9234 / 760-431-2100 (Ext. 138) or Support@Simply-Automated.com or see http://www.simply-automated.com/Anywhere_Virtual_3-way_Applications.php